

DELHI AVIATION FUEL FACILITY (P) LIMITED

Request for Quotation (RFQ)

FOR

Supply of 24” Expansion Joint
(TIED DOUBLE METAL BELLOW EXPANSION JOINT)

TABLE OF CONTENTS

Section	Document description	Page No.
1.	Request for Quotation	3
2.	Company Profile	4
3.	Specification Sheet	5
4.	Terms & Conditions	5
5.	Price Schedule	Annexure 1

Section-1 REQUEST FOR QUOTATION

DAFFPL invites sealed quotations for supply of 24” Expansion Joint (TIED DOUBLE METEL EXPANSION JOINT) as per specification sheet as required.

The interested parties are advised to adhere to the following schedule for this Request for Quotation and submit their queries, replies & quotations at details mentioned below:

Date of issuance of Request for Quotation	:	13 th October 2017
Last date for Quotation submission	:	31 st October 2017 15:00 Hrs
Place of submission	:	DAFFPL, Aviation Fuelling Station, Shahabad Mohammadpur, New Delhi-110061.

“NO QUOTATION WILL BE CONSIDERED AFTER THE LAST DATE & TIME FOR QUOTATION SUBMISSION”

Contact Details:

For any further information about the company, please visit www.daffpl.in

Further, for any updation, clarification and amendment, please visit our website on regular intervals.

You can also contact at the following details:

Mr. M Vishnu Vardhan (Project officer)

8826000228, Email: vishnu.vardhan@daffpl.in

Mr. Manish Kumar (Assistant Project Officer)

9810640818, Email: manish.kumar@daffpl.in

Section-2

COMPANY PROFILE

Delhi Aviation Fuel Facility Private Limited (DAFFPL) is a Joint Venture of two “Fortune 500” companies namely Indian Oil Corporation Limited (IOCL), Bharat Petroleum Corporation Limited (BPCL) and Delhi International Airport Private Limited (DIAL), a GMR group company. Further details may be obtained from our website www.daffpl.in

Section-3

MATERIAL SPECIFICATION SHEET

Specification Sheet attached as Annexure-A

Section-4

TERMS & CONDITIONS

1. The bidder should be able to supply the entire type bid by them. Bidders cannot bid for part items or part quantity of a lot.
2. The quotation submitted should be valid for **four months** from the due date of bid submission for Owners acceptance. Once accepted it will remain firm till completion of contracts/orders.
3. The bidders to provide their bank details/ PAN / GST Registration number as applicable for updating bidder master file. You are also requested to keep us informed of any change in address / status of your business / contact details including email address etc.
4. DAFFPL reserves the right to accept any quotation in whole or in part or reject any or all quotations without assigning any reason. Decision of DAFFPL in this regard shall be final and binding on the bidder.
5. **GOVERNING LAWS:** The laws of Union of India shall govern all matters concerning the RFQ. Any issue arising related to the RFQ or the selection process shall be adjudged by the courts in Delhi alone.
6. Owner is not responsible for any delays from bidder end.
7. Owner reserves the right to make any changes in terms and conditions of purchase before due date of bid submission and to reject any or all bids received incomplete.
8. DAFFPL reserves their right to negotiate the quoted prices with lowest bidder.
9. Owner's decision on any matter regarding short listing of bidders shall be final and no corresponding in this regard will be entertained.
10. The bidders who are on IOCL/BPCL/DIAL holiday list or delisted will not be considered.
11. **DELIVERY PERIOD:**
The items covered in this enquiry are required to be delivered as per Delivery Schedule stipulated below.
 - a) **DELIVERY PERIOD**
 - i. Item should be delivered within 02 months from date of notification of award.
 - b) Delivery Period shall be counted from the date of notification of award (Letter/Fax/e-mail of Intent) up to the Date of receipt of goods at defined locations.

13 PRICE REDUCTIONS FOR DELAY IN DELIVERY:

- a) The delivery period quoted must be realistic & specific. The inability of successful bidder to execute orders in accordance with the agreed delivery schedule will entitle DAFFPL, at its options, to:
- b) Accept delayed delivery at prices reduced by a sum equivalent to half percent (0.5%) of the value of any goods not delivered for every week of delay or part thereof, limited to a maximum of 10% of the total order value. Date of receipt of materials at owner's premises shall be considered for calculation of price reduction.

14. INSURANCE

Supplier shall carry and maintain any and all statutory insurance(s) required under Indian Laws and Regulations, including Workmen Compensation Act/ESI/Third party liabilities etc. and insurances for their personnel engaged in performance of the work at their own cost.

15. PAYMENT TERMS

- a) Bidders to note that Advance Payment is not permissible in the contract.
- b) The following payment terms shall be applicable :
 - 80% payment will be released within 30th day from the receipt and acceptance of materials at site adjusting deductible if any.
 - 10% after completion for Installation, Testing & Commissioning.
 - 10% (Retention Amount) after completion of guarantee/warranty period or after submission of Bank Guarantee. The Bank Guarantee (equal to TEN PERCENT (10%) of the Total Order Value) shall be valid for the entire period of the Contract, namely, till the end of the guarantee / warranty period.

16. GUARANTEE/WARRANTY:

- a) Materials shall be guaranteed against manufacturing defects, materials, workmanship and design for a period of 12 months from the date of commissioning. Warranty for replacement of material / accessories should be provided free of charges at our premises. The above guarantee/warranty will be without prejudice to the certificate of inspection or material receipt note issued by us in respect of the materials.

17. TEST & PERFORMANCE CERTIFICATES: Bidder shall furnish Material test and Performance Certificates for the materials along with the challans and invoice.

18. Any reference to the Govt. Acts /Regulations etc. in the Bid Document is only indicative, and it is entirely for the bidder to ascertain the applicable Acts/Regulations.

19. COMPLIANCE OF REGULATIONS: Bidder warrants that all goods/Materials covered by this order have been produced, sold, dispatched, delivered and furnished in strict compliance with all applicable laws, regulations, labour agreement, working condition and technical codes and statutory requirements as applicable from time

to time. The bidder shall ensure compliance with the above and shall indemnify owner against any actions, damages, costs and expenses of any failure to comply as aforesaid.

20. NEW & UNUSED MATERIAL: All the material supplied by the bidder shall be branded new, unused and of recent manufacture.

21. CANCELLATION:

- a) DAFFPL reserves the right to cancel the contract/purchase order or any part thereof through a written notice to the bidder if –
 - i. The bidder fails to comply with the terms of this purchase order/contract.
 - ii. The bidder becomes bankrupt or goes into liquidation.
 - iii. The bidder fails to deliver the goods on time and/or replace the rejected goods promptly.
 - iv. The bidder makes a general assignment for the benefit of creditors.
 - v. A receiver is appointed for any of the property owned by the bidder.
 - vi. Any other conditions where owners commercial interest get affected.

	CLIENT : DELHI AVIATION FUEL FACILITY PVT. LTD,	EM244-0000-1601	0
	PROJECT : ROOT CAUSE ANALYSIS OF UNDUE STRESS ON EXPANSION BELLOW OF TANK VF203	DOCUMENT NO	REV
	LOCATION : AVIATION FUELLING STATION, NEW DELHI	SHEET 1 OF 5	

SPECIFICATION SHEET - EXPANSION JOINT (24") MDS-EJ-VF203

0	12.09.17	ISSUED	BKC	DD	AMAR
REV	DATE	PURPOSE	PREPD	REVWD	APPD

	CLIENT : DELHI AVIATION FUEL FACILITY PVT. LTD,	EM244-0000-1601	0
	PROJECT : ROOT CAUSE ANALYSIS OF UNDUCE STRESS ON EXPANSION BELLOW OF TANK VF203	DOCUMENT NO	REV
	LOCATION : AVIATION FUELLING STATION, NEW DELHI	SHEET 2 OF 5	

SPECIFICATION SHEET -TIED DOUBLE METAL BELLOWS EXPANSION JOINT

GENERAL:

ITEM NO.: MDS-EJ-VF203 QUANTITY: ONE PIPE SIZE: 24" O/D
OVER ALL LENGTH: 1100 mm INSTALLATION: HORIZONTAL
TYPE: TIED DOUBLE METAL BELLOWS EXPANSION JOINT.
(CHECK ONE) EQUALIZING NON-EQUALIZING
APPLICABLE SKETCH NO: AS PER ENCLOSED SKETCH.
DESIGN:

SERVICE/FLOW MEDIUM : ATF	FLOW VELOCITY : 22700 lit/min.
ATTACHED LINE MATERIAL : API 5L GR. X42 SAW	CORROSION ALLOWANCE: 2.0 mm
OPERATING/DESIGN PRESSURE : 7kg/cm2g/ 15kg/cm2g	TEMPERATURE : 100° C
SHORT TIME PRESSURE:	TEMPERATURE :

TYPE OF SHORT TIME CONDITION:

- LESS THAN 10 HOUR AT ANY TIME 100 HOUR
 LESS THAN 50 HOUR AT ANY TIME 500 HOUR

INTERNAL LINER REQUIRED? YES NO

(IF YES) MATERIAL : API 5L GR. X42 SAW MINIMUM THICKNESS : 12.7 mm

MOVEMENTS: AXIAL: 15 mm WITHIN TIE-ROD LATERAL OFFSET: 75 mm

NOTES : SEE SPECIAL NOTES

ALLOW. AXIAL STIFNESS (K): 1247 Kg/cm

ALLOW. TRANSLATERAL STIFNESS (K): 43722 Kg/cm

ALLOW. TORSIONAL STIFNESS (K): 72958 Kg-m/deg.

VALUES PROPOSED BY SUPPLIER SHALL BE CHECKED FOR ACCEPTABILITY IN STERSS ANALYSIS

UPSTREAM CONNECTION: FROM TANK DOWNSTREAM CONNECTION: TO HEADER

SIZE : 24"	SIZE : 24"
RATING/END : 150# SORF, AS PER ASME B16.5	RATING/END : 150# SORF, AS PER ASME B16.5
BORE :	BORE :
THICKNESS: 12.7 min.	THICKNESS: 12.7 min.

BELLOWS MATERIAL: SS304L

MINIMUM THICKNESS: 6 mm

CENTER SPOOL MATERIAL: : API 5L GR. X42 SAW

CORROSION ALLOWANCE: 2.0 mm

(FOR DOUBLE BELLOWS)

0	12.09.17	ISSUED	BKC	DD	AMAR
REV	DATE	PURPOSE	PREPD	REVWD	APPD

	CLIENT : DELHI AVIATION FUEL FACILITY PVT. LTD,	EM244-0000-1601	0
	PROJECT : ROOT CAUSE ANALYSIS OF UNDUE STRESS ON EXPANSION BELLOW OF TANK VF203	DOCUMENT NO	REV
	LOCATION : AVIATION FUELLING STATION, NEW DELHI	SHEET 3 OF 5	

EXTERNAL SHEILD FOR OPERATION REQUIRED? : YES – REMOVABLE TYPE (SEE NOTE 12)

MINIMUM DESIGN CYCLES: 7000 CYCLES PER ASME B31.3 APPENDIX 'X'

DESIGN, FABRICATION, TESTING & INSPECTION:

CODE: ASME B31.3 LATEST EDITION

PRESSURE TEST (BY MANUFACTURER): HYDROTEST OF BELLOW AS PER CODE
BY FIELD: NONE

WELD EXAMINATION FOR PRESSURE CONTAINING OR RESTRAINING PARTS: PER CODE B31.3
EXTERNAL SHIPPING SHIELD REQUIRED FOR THE BELLOW (SEE NOTE 13): YES - REMOVABLE
IDENTIFICATION NO.: MDS-EJ-VF203

REQUISITION NUMBER:

MARK NUMBER : MDS-EJ-VF203

LINE NUMBER : -

0	12.09.17	ISSUED	BKC	DD	AMAR
REV	DATE	PURPOSE	PREPD	REVWD	APPD

	CLIENT : DELHI AVIATION FUEL FACILITY PVT. LTD,	EM244-0000-1601	0
	PROJECT : ROOT CAUSE ANALYSIS OF UNDUE STRESS ON EXPANSION BELLOW OF TANK VF203	DOCUMENT NO	REV
	LOCATION : AVIATION FUELLING STATION, NEW DELHI	SHEET 4 OF 5	

SPECIAL NOTES:

1. THE EXPANSION JOINT TO BE CLEAN AND FREE FROM ALL LOOSE MATERIAL.
2. THE EXPANSION JOINT ARE TO BE SUPPLIED AS SEPERATE ITEMS AS SHOWN IN THE ATTACHED SKETCH AND IN LOCKED CONDITION.
3. DESIGN CONDITIONS:
DESIGN PRESSURE: **15kg/cm2g**
DESIGN TEMPERATURE: **100°C**
4. MATERIAL SPECIFICATION:
BELLOWS MATERIAL: **SS304L**
DUCT (PIPE): **API 5L GR. X42 SAW**
STIFFENERS: **ASTM A36**
ATTACHMENT PLATES: **ASTM A 36**
5. VENDOR SHALL FURNISH CALCULATIONS AND DETAIL FABRICATION DRAWING OF EXPANSION JOINT TO PURCHASER FOR THEIR APPROVAL.
6. THE SHIPPING AND UNCRATED WEIGHT OF THE ASSEMBLY SHALL BE ESTIMATED WITHIN 5% AND PROVIDED WITH QUOTATION.
7. TEMPORARY SHIPPING RESTRAINTS SHALL BE ADEQUATELY DESIGNED TO WITHSTAND SHIPPING AND HANDLING IN FIELD.
8. ALL INTERNAL WELDS TO BE GROUND SMOOTH AND FLUSH.
9. LIFTING LUGS TO BE SUPPLIED BY VENDOR.
10. COATING SYSTEM : **AS PER MANUFATURER'S STANDARDS**
11. BELLOWS INTERNAL LINER SHALL BE PROVIDED WITH DRAIN HOLES.
12. EXTERNAL COVER SHALL BE STRONG ENOUGH TO PROVIDE PROTECTION DURING TRANSPORTATION, HANDLING, FIELD STOARGE AND INSTALLATION.

0	12.09.17	ISSUED	BKC	DD	AMAR
REV	DATE	PURPOSE	PREPD	REVWD	APPD

TIE ROD EXPANSION BELLOW (MDS-EJ-VF203)

PROJECT : ROOT CAUSE ANALYSIS OF UNDUE STRESS ON EXPANSION BELLOW OF TANK VF203
CLIENT : DELHI AVIATION FUEL FACILITY PVT. LTD, NEW DELHI

EM244-0000-1601	0
DOCUMENT No.	REV.
SHEET 5 OF 5	

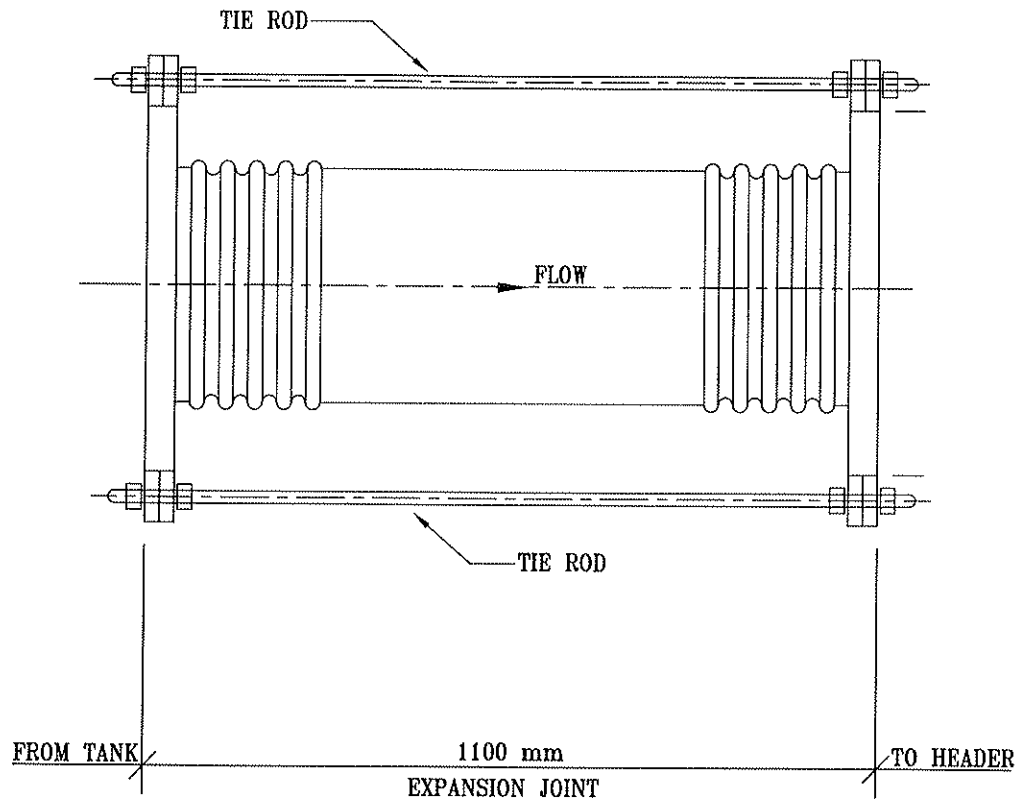

SIZE: 24" O/D, END-150# AS PER ASME B16.5

NOTE: TO BE INSTALLED IN HORIZONTAL

0	12.09.17	ISSUED	SATYA	DD	AMAR
REV	REV DATE	PURPOSE	PREPARED	REVIEWED	APPROVED



DELHI AVIATION FUEL FACILITY PRIVATE LIMITED

PRICE SCHEDULE FOR SUPPLY OF 24" EXPANSION JOINT

S No	ITEM DESCRIPTION	Unit	QTY	Unit Rate (in Rs.) for			Total Amount (F.O.R Site) in Rs. (5+6+7+8)	
				Supply Ex. Works including Packing & Forwarding	GST			Freight Transit Insurance FOR Site
					%	Amount		
1	2	3	4	5	7	8	9	
A	24" Expansion Joint (TIED DOUCBLE METEL BELLO EXPANSION JOINT) as per Specifications provided.	No	01					
Total Amount in Words								

***NOTE:**

1. DAFFPL will not provide C-FORM.
2. If Bidder claims for Freight Insurance, copy of the same has to be provided.

Sign & Stamp of Bidder